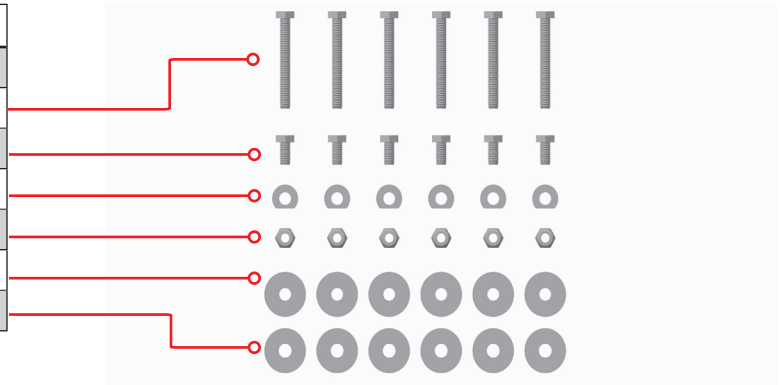


Parts Included:	
Description	Qty.
Screw, 1/4-20 x 2" HHCS SS	6
Screw, 1/4-20 x 0.5 HHCS SS	6
Washer-Clipped, 1/4", 1" OD	6
Nut, 1/4-20 Nylock SS	6
Washer, 1/4" Flat 18-8 SS	6
Washer-Mounting, Rubber	6



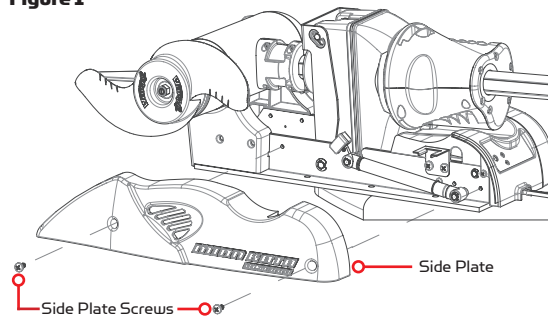
### Tools and Resources Required:

- Drill
- 5/16" Drill Bit
- 7/16" Wrench
- 9/16" Wrench (for prop)
- Wire Ties (for cable routing)
- Phillips Screwdriver
- Flat Blade Screwdriver

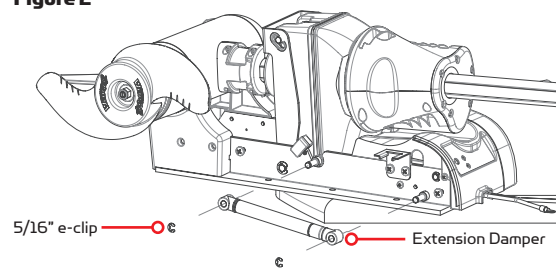
### Installation Instructions:

1. Remove the four sideplate screws. Remove sideplates to access the mounting holes. (Figure 1)

**Figure 1**

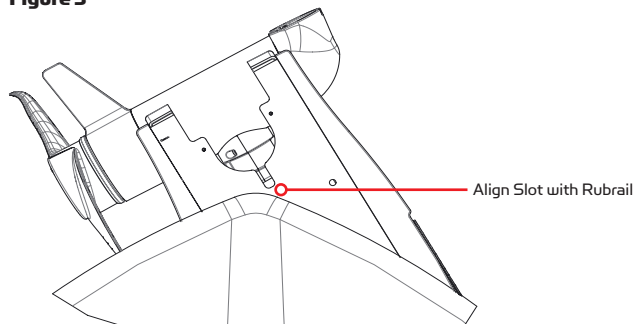


**Figure 2**

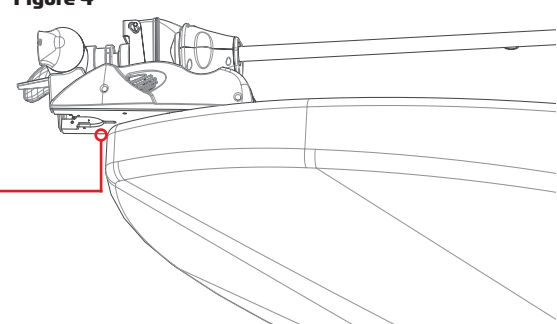


2. Remove the two 5/16" e-clips retaining the extension damper. Remove the extension damper to expose the front left mounting hole. (Figure 2)
3. Place the motor on the bow of the boat. It is recommended that the motor be mounted as close to the centerline of the boat as possible. Make sure the slot on the underside of the mounting base is aligned with the rubrail of the boat. This will ensure that the shaft has a minimum clearance of 1-1/2" when it is deployed. (Figure 3 & 4)

**Figure 3**



**Figure 4**



4. Once the motor is positioned, mark at minimum, four of the six holes that are located farthest apart (at least two on each side). Make sure the area under the mounting location is clear to drill holes and install nuts and washers. Drill through the marked holes using a 5/16" drill bit.
5. Mount the motor to the boat using the provided hardware. Install the hex head bolts and clipped washers on the right side of the motor as viewed from the boat interior. (Figure 5) Motor can then be slid into place utilizing the slots on the motor base plate. Clipped washer should be oriented with the flat portion against the mounting base. (Figure 6)

Figure 5

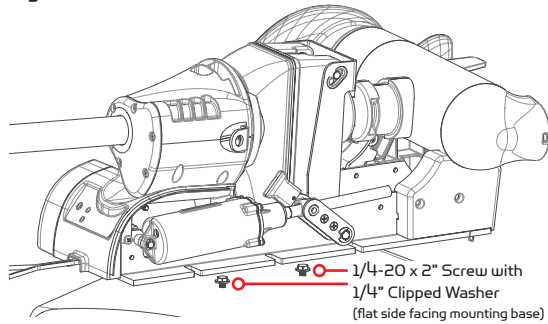
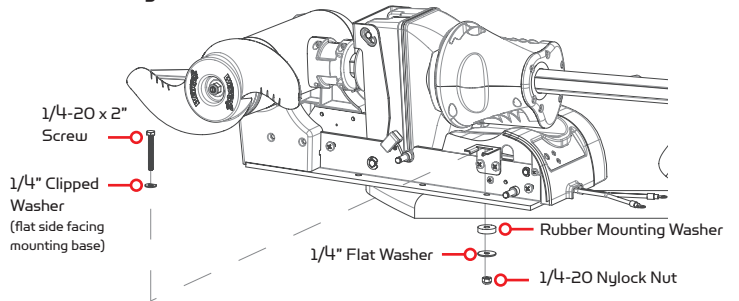


Figure 6



6. Reinstall the extension damper with the shaft facing toward the interior of the boat. Reinstall the e-clips. (Figure 7)

Figure 7

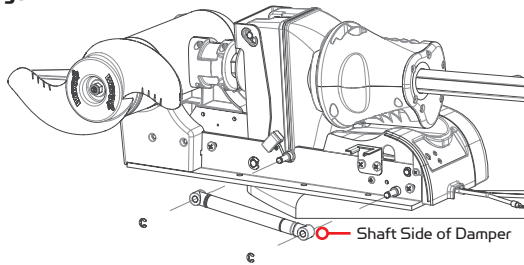
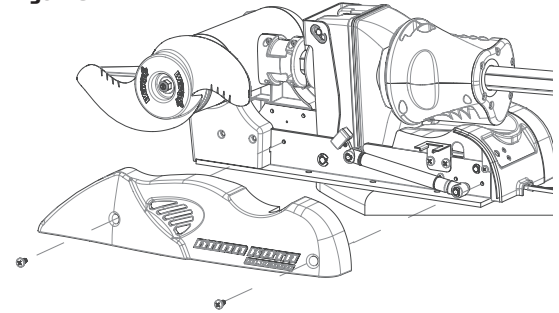
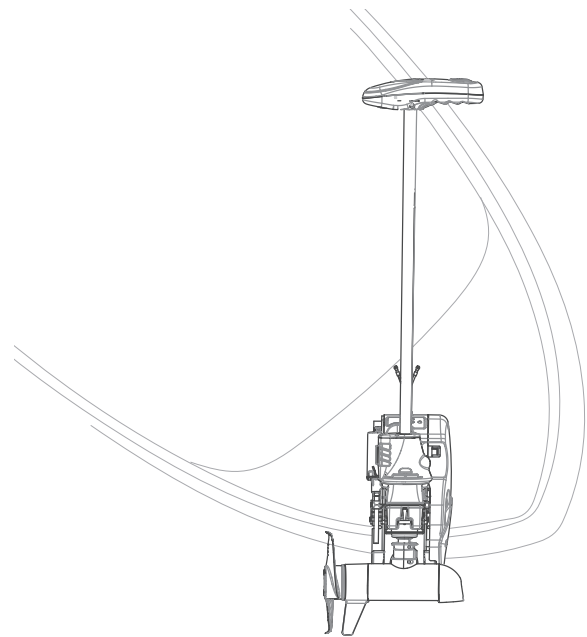
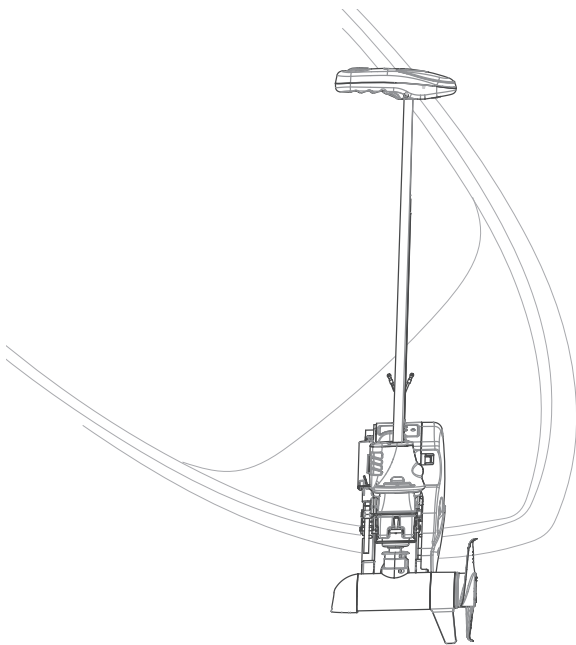


Figure 8



7. Replace the sideplates and sideplate screws by hand using a Phillips screwdriver. (Figure 8) **Note:** Do not use a power tool to install these screws.
8. Connect the motor to power and sonar cable to depth finder using the appropriate adapter cable (sold separately).
9. The user has the option of stowing the prop oriented in or out to accommodate different boat cover configurations. Follow the procedure in the Mounting Options section of the Ulterra manual to change prop orientation.



For warranty information please visit [www.minnkotamotors.com](http://www.minnkotamotors.com)

WARNING: This product contains chemicals known to the State of California to cause cancer and birth defects or other reproductive harm.



[minnkotamotors.com](http://minnkotamotors.com)

Minn Kota Consumer & Technical Service  
 Johnson Outdoors Marine Electronics, Inc.  
 PO Box 8129  
 Mankato, MN 56001

121 Power Drive  
 Mankato, MN 56001  
 Phone (800) 227-6433  
 Fax (800) 527-4464



©2014 Johnson Outdoors Marine Electronics, Inc.  
 All rights reserved.